

Augmented Pixel Datasheet

<http://www.niklasroy.com/project/101/PING>

Pinout:

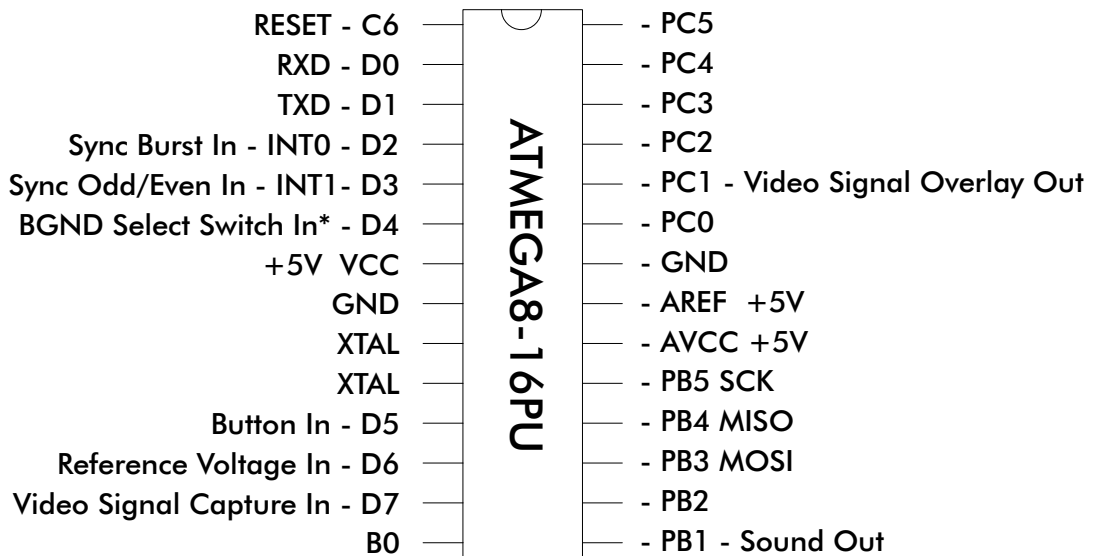
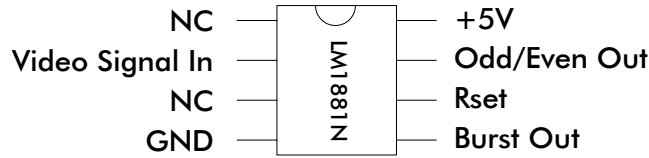

* "BGND Select Switch In" is not supported in current Firmware

Circuit Diagram:

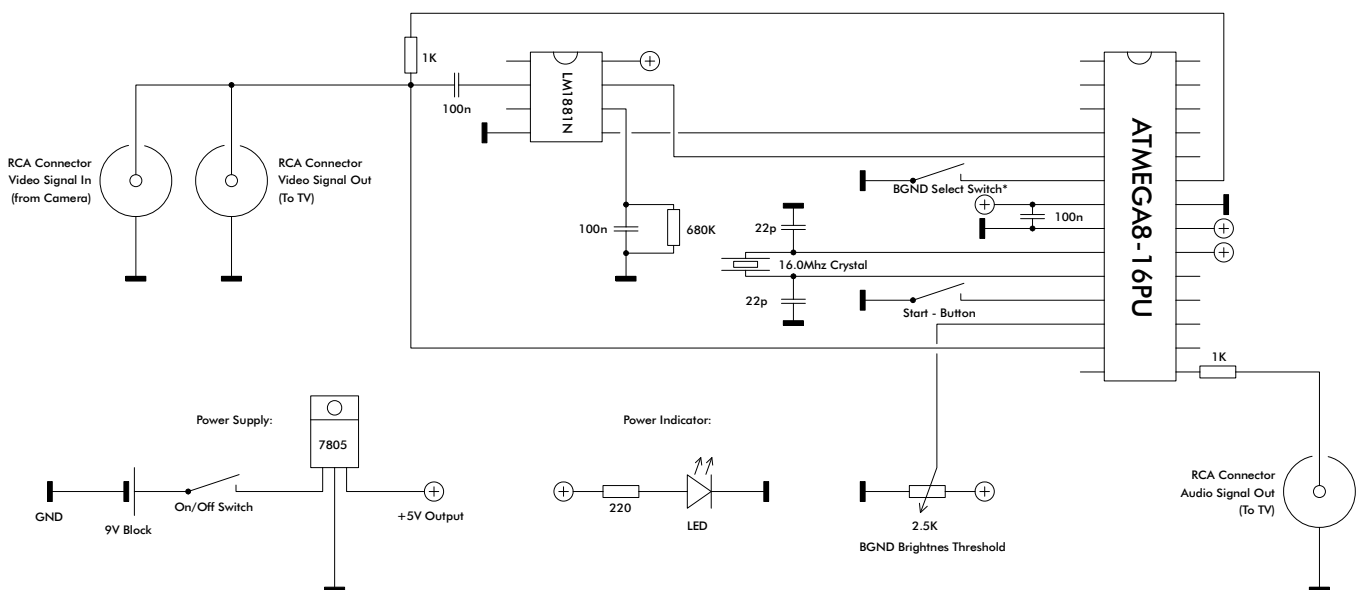

Perfboard Layout:

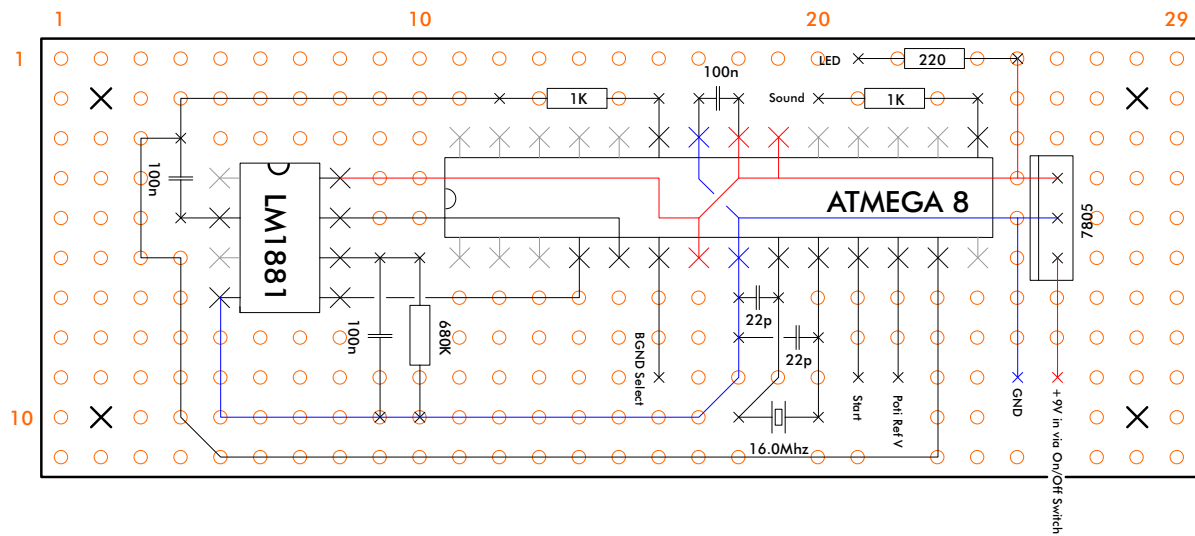

Parts List:

IC's:

ATmega8-16PU

(Microcontroller)

LM1881N

(Video Sync Separator)

7805

(5V Positive Voltage Regulator)

Crystal:

16MHz

Capacitors:

2x 22nF

3x 100nF

Resistors:

2x 1K

1x 220 Ohm

Interface:

5mm red LED

Button

Switch

2.5K Linear Poti

9V Battery Clip

Epoxy Perfboard 11x29